

**TOSUN**



# TO1013 Product Manual

Version: V1.0 | English

[tosunai.com](http://tosunai.com)

#### Copyright Information

Shanghai TOSUN Technology Ltd

No. 9 Building, 1288 Jiasong North Road, Jiading District, Shanghai (Headquarters)

Buildings 14-17, Lane 4849 Cao'an Highway (Shanghai Research Institute)

In the principle of providing better services to users, Shanghai TOSUN Technology Ltd (hereinafter referred to as "TOSUN Technology") will present as much detailed and accurate product information as possible in this manual. However, due to the timeliness of the content in this manual, TOSUN Technology cannot fully guarantee the timeliness and applicability of this document at any time.

If there are any changes to the information and data in this manual, no separate notice will be given. To obtain the latest version of the information, please visit the [official website of TOSUN Technology](#) or contact the staff of TOSUN Technology. Thank you for your understanding and support!

Without the written permission of TOSUN Technology, no part of this manual may be copied in any form or by any means.

@ Copyright 2024, Shanghai TOSUN Technology Ltd. All rights reserved.

## What Is the TO1013?

TO1013 is a dual-channel CAN (FD) to fiber optic tool. It has similar CAN/CANFD bus functionalities as the TC1013 and TP1013 devices. Compared to the TC1013 and TP1013, the TO1013 offers a superior transmission medium solution, which is fiber optic.

## What Are the Advantages of Fiber Optic?

- Lower transmission loss;
- Longer transmission distances;
- Stronger anti-interference performance;
- Higher security;
- Better environmental adaptability.

## What Can They Do?

- Bus data collection;
- Domain controller testing;
- Various automated testing systems;
- UDS diagnostics and calibration with CCP and XCP;
- Offline/online replay for blf and asc format files;
- ECU flashing;
- EMC anechoic chamber testing;
- ...



## How to Use TO1013?

After connecting the TO1013 device to a PC, use a fiber optic cable to connect to the TO1013 Isolator for medium conversion. By connecting the ECU via a DB9 signal cable to the TO1013 Isolator, on the PC, users can perform CAN/CANFD communication between the device and ECU using the powerful TSMaster software.

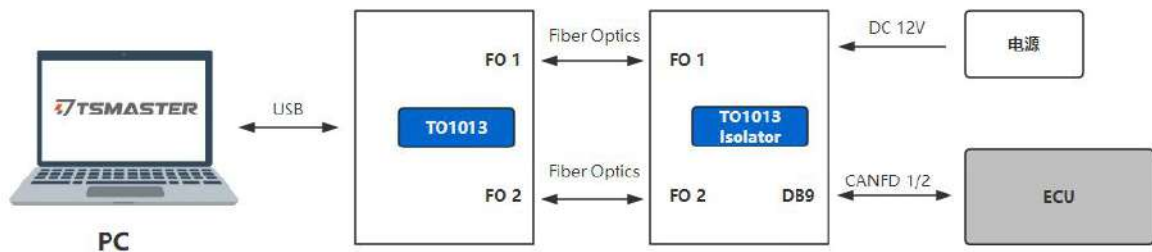

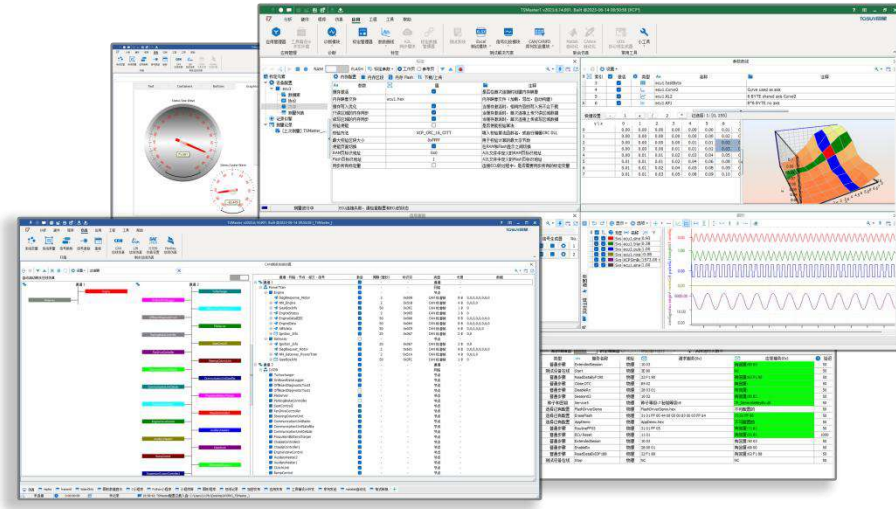

## Contents

1. About this User Manual .....	7
1.1 Warranty .....	7
1.2 Copyright .....	7
2. TO1013 .....	8
2.1 Product Overview .....	8
2.2 Features .....	9
2.3 Technical Data .....	9
2.4 Electrical Data .....	10
2.5 Mechanical Data .....	12
2.6 Scope of Delivery .....	12
2.7 Hardware Interface .....	14
2.8 LED .....	15
2.9 Optional Accessories .....	17
3. Quick Start .....	17
3.1 System Connection .....	17
3.2 Driver Installation .....	17
3.3 Software Overview .....	18
3.4 Software Installation .....	19
3.5 Use TSMaster with the Hardware .....	19
4. Inspection and Maintenance .....	21
5. Appendix .....	22

## **1. About this User Manual**

### **1.1 Warranty**

This document is provided for reference only and does not constitute any form of guarantee or commitment from TOSUN. TOSUN Technology reserves the right to modify the content and data of the document without further notice. TOSUN Technology assumes no responsibility for the accuracy of the document or for any damages arising from the use of the document. TOSUN Technology greatly appreciates for pointing out errors or making suggestions for improvement, so that we can provide more efficient products in the future.

### **1.2 Copyright**

TOSUN Technology retains all rights to this document and its contents. Without the explicit written permission of TOSUN Technology, it is prohibited to copy, distribute, transmit, disseminate, republish, or use any part of this document in any manner.

## 2. TO1013

### 2.1 Product Overview

TO1013 is a dual-channel CAN (FD) to fiber optic tool launched by TOSUN. It supports a maximum CANFD bus rate of 8 Mbps. The product uses fiber optic as the data transmission medium, which reduces transmission loss and significantly increases transmission distance. Additionally, fiber optic offers excellent EMI and EMC characteristics, further enhancing the device's anti-interference performance.

With the powerful TSMaster software, it supports loading DBC and ARXML database files, making it very convenient to monitor, analyze, and simulate CAN bus data. It also supports functions such as UDS diagnostics, ECU flashing, CCP/XCP calibration, etc.

The secondary development APIs for Windows and Linux can support various development environments such as C++, C#, LabView, Python, etc., making it highly efficient and easy to use, and is convenient to integrate into various testing systems.





## 2.2 Features

- ✓ 1 us (microsecond) level hardware message timestamps to meet advanced requirements;
- ✓ The PC side features a USB 2.0 interface, with a driverless design for Windows and Linux systems, offering excellent system compatibility;
- ✓ Uses latest CAN FD bus opto-isolator;
- ✓ Equipped with built-in ESD and surge protectors;
- ✓ CAN channel baud rate adjustable from 125Kbps to 1Mbps, and CANFD supports a maximum of 8Mbps;
- ✓ Automotive-grade design, supporting dbc files, a2l files, blf files, and asc files;
- ✓ Supports blf and asc format data recording and offline/online playback;
- ✓ Supports UDS diagnostics and CCP/XCP calibration;
- ✓ Supports UDS based Bootloader flashing;
- ✓ Supports secondary development interfaces for Windows and Linux systems;
- ✓ Built-in 60/120-ohm terminal resistor, with the resistance value configurable using a toggle switch;
- ✓ CAN channel capacitance to ground is configurable at 22pF/470pF using a toggle switch.

## 2.3 Technical Data

Channel	2* CANFD
PC Side	USB 2.0 interface
CAN Side	DB9 interface
Driver	Driverless design for Windows and Linux systems, offering excellent system compatibility
Cache	Hardware cache, with each channel's transmission buffer supporting up to 1000 CAN frames
CAN	Supports CAN 2.0 A and B protocols, compliant with the ISO 11898-1 standard, with baud rates from 125Kbps to 1Mbps
CANFD	Supports CAN FD that complies with both ISO and non-ISO standards, with baud rates from 125Kbps to 8Mbps
Timestamp Accuracy	1 us, hardware message timestamp, can meet advanced requirements
Terminal Resistor	Built-in 60/120-ohm terminal resistor, with the resistance value configurable using a toggle switch
Capacitance to Ground	CAN channel capacitance to ground is configurable at 22pF/470pF using a toggle switch
Messages Sent	Up to 20,000 frames per second

per Second*	
Messages Received per Second*	Up to 20,000 frames per second
Insulate	Opto-isolation
Power Supply	USB power supply + DC power supply (12V)
Power Consumption	2.5W
Case Material	Metal
Dimension	Approx. 109*97*35mm
Weight	Approx. 429g (without packaging)/Approx. 1132g (with packaging)
Operating Temperature	-40°C~80°C
Operating Humidity	10% ~ 90% (non-condensing)
Operating Environment	Keep away from corrosive gases

\*Single channel 1Mbps, with a 0-byte data field.

## 2.4 Electrical Data

Parameter		Test Condition	Minimum Value	Typical Value	Maximum Value	Unit
Operating Voltage	USB power supply (main device)	CAN transmission	4.8	5.0	5.2	V
	DC power supply (isolator)	CAN transmission	9	12	15	V
Operating Current	USB power supply (main device)	CAN transmission	--	0.25	--	A
	DC power supply (isolator)	CAN transmission	--	0.96	--	A
Power Consumption	USB/DC total	CAN transmission	--	2.4	--	W
CAN Interface	Bus pin voltage resistance	CANH、CAHL	-58	--	58	V

	Terminal resistor	Terminal resistor enabled	60	--	120	$\Omega$
	Capacitance to ground	Capacitance to ground enabled	22	--	470	pF
EMC Compati bility	ESD	IEC61000-4-2 standard	Contact discharge: 4 Air discharge: 8	--	--	kV
	EFT	IEC61000-4-4 standard	2	--	--	kV
	Surge	IEC61000-4-5 standard	2	--	--	kV

## 2.5 Mechanical Data

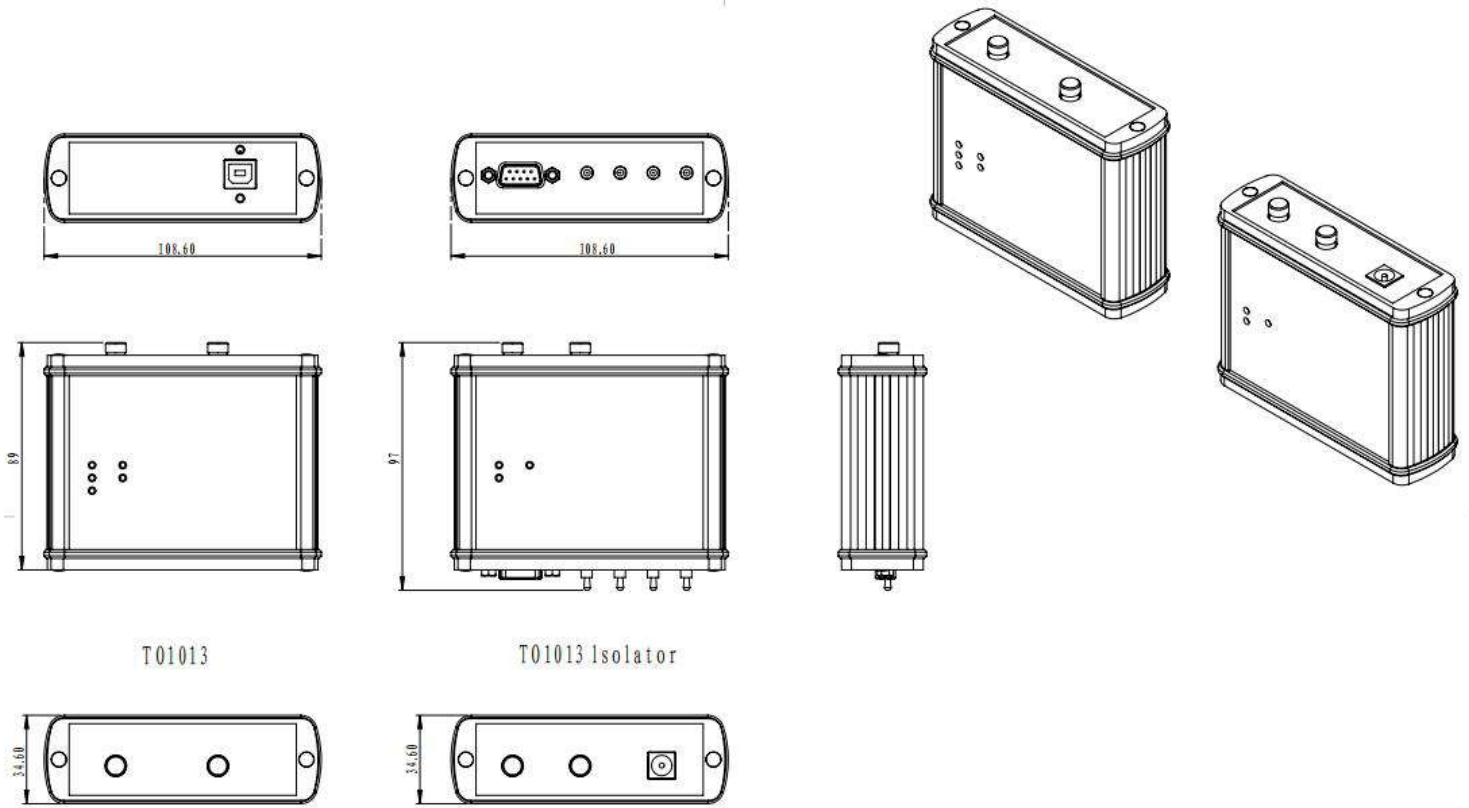

T01013

T01013 Isolator

材质 Material		一般公差 General Tolerances	表面处理 Surface Treatment	工艺tech.
A3		设计draw.	审核audi.	批准appr.
SCALE:1/2	SHEET 1 OF 1			
<b>TOSUN</b>				重量(g) Weight
上海阿星智能科技有限公司 SHANGHAI TONGSHING INTELLIGENT TECHNOLOGY CO., LTD		T01013		版本 Rev. 00

## 2.6 Scope of Delivery

- ✓ Main device: T01013



- ✓ TO1013 isolator



- ✓ 12V2A power adapter



- ✓ FC-FC single-mode single-core fiber optic cable \*2;



- ✓ DB9 female to dual male signal cable (CAN)



## 2.7 Hardware Interface

**TO1013 main device:**

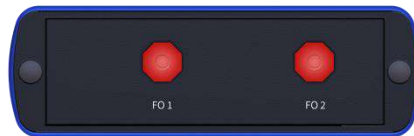

- USB2.0 interface;
- Fiber optic connector.

**TO1013 Isolator:**

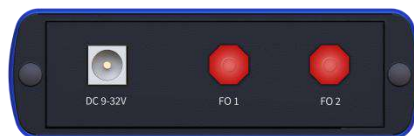

- DB9 interface:

DB9 PIN	PIN Number	Definition

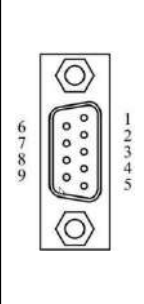
	PIN2	CANFD1_Low
	PIN3	CANFD_GND
	PIN4	CANFD2_Low
	PIN5	CANFD_Shield
	PIN7	CANFD1_High
	PIN8	CANFD2_High

- Toggle switch;
- DC power input port;
- Fiber optic connector.

## 2.8 LED

**TO1013 main device:**

Diagram of LED indicator:



Description of indicator:

Indicator	Definition
FO 1	Indicator for fiber channel 1
FO 2	Indicator for fiber channel 2
CANFD 1	Indicator for CANFD channel 1
CANFD 2	Indicator for CANFD channel 2
LINK	Indicator for hardware connection

Description of LED color:

Color	Description
FO Green	Fiber link is normal
CANFD Green	CANFD channel data frame is sent or received correctly
CANFD Red	CANFD channel sends or receives error frames, indicating a configuration, protocol, or wiring error
LINK Green	The device is connected

Note: The blinking frequency depends on the bus load.

### TO1013 Isolator:

Diagram of LED indicator:



Description of indicator:

Indicator	Definition
FO 1	Indicator for fiber channel 1
FO 2	Indicator for fiber channel 2
Power	Indicator for power

Description of LED color:

Color	Description
FO Green	Fiber link is normal
Power Green	Device power is normal



## 2.9 Optional Accessories

N/A.

## 3. Quick Start

### 3.1 System Connection

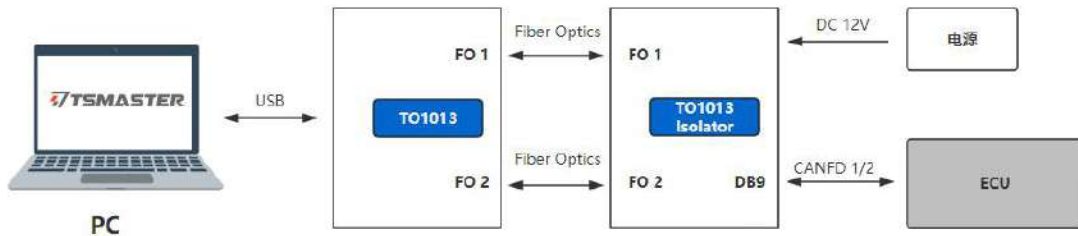

Connect the TO1013 main device to the PC via USB, and link the two fiber optic interfaces to the TO1013 Isolator using fiber optic cables. After media conversion through the TO1013 Isolator, users can use a standard DB9 signal cable to connect to the ECU. On the PC side, the powerful TSMaster software can control the communication between the TO1013 device and the ECU using CAN/CANFD protocols. The TO1013 Isolator is equipped with built-in 60/120 ohm terminal resistors and 22pF/470pF to-ground capacitance, which can be configured using the toggle switch on the device.

### 3.2 Driver Installation

All TOSUN hardware adopts a driverless design, offering excellent system compatibility. The hardware allow for direct use on various operating systems (Windows 7/8/10/11, Linux) without the need to install drivers.

### 3.3 Software Overview

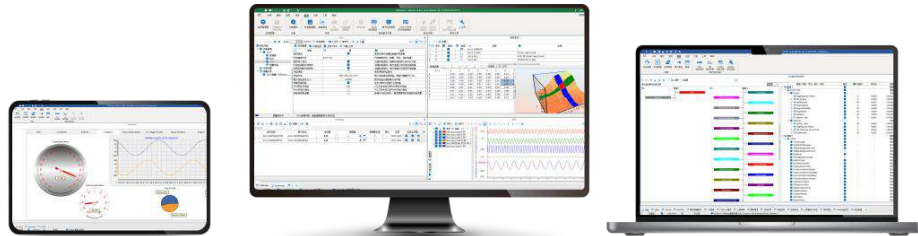

TSMaster is a powerful and comprehensive tool that can connect, configure, and control all TOSUN hardware tools and devices, enabling functions such as automotive bus embedded code generation, monitoring, simulation, development, UDS diagnostics, CCP/XCP calibration, ECU flashing, I/O control, test measurement, and so on.

TSMaster supports Matlab Simulink co-simulation and CarSim dynamic model ECU algorithm simulation testing (soft real-time HIL). It provides users with a series of convenient functions and editors, allowing them to directly execute ECU code within TSMaster and supports C script and Python script editing. At the same time, TSMaster also offers a mini-program function, enabling users to customize the simulation test panel, test process, test logic, and even the entire test system, and automatically generate reports. The code written by users based on TSMaster is hardware-independent, and can be easily shared, referenced, and used on different hardware platforms.

TSMaster supports multiple commonly used bus tool brands, including Vector, Kvaser, PEAK, IXXAT, as well as mainstream instruments in the market (such as oscilloscopes, waveform generators, and digital multimeters) and boards (such as AI, DI, DO, etc.). Its design concept is to perfectly integrate with the test system to achieve joint simulation and testing of multiple hardware and multiple channels. This enables TSMaster to meet the PV/DV test verification needs for various automotive electronic components and assemblies, as well as the inspection requirements for the production line.

### 3.4 Software Installation

TSMaster software download link:

[http://download.tosun.tech/TOSUNSoftware/TSMaster\\_Setup\\_beta.7z](http://download.tosun.tech/TOSUNSoftware/TSMaster_Setup_beta.7z)

If the link is not accessible, you can contact the corresponding sales personnel or visit the official TOSUN website to obtain the software. Meanwhile, you can scan the QR code to follow the TOSUN official account to get the download link.



After the installation, you can see the following software on the PC.



### 3.5 Use TSMaster with the Hardware

In TSMaster, click Hardware-Channel Selection. In the channel selection GUI, select the device you want to connect.

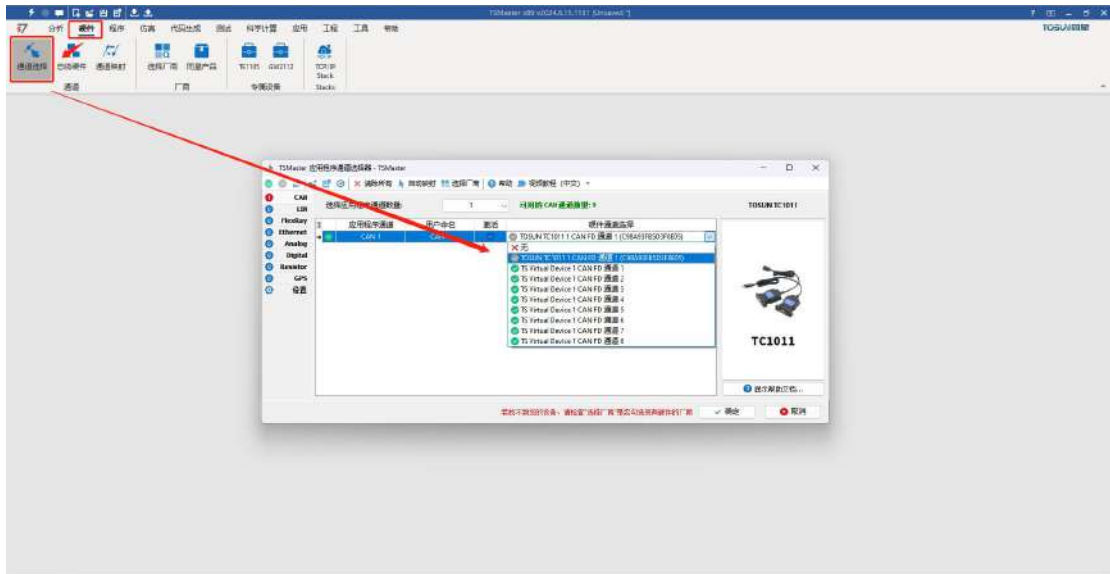

In Network Hardware, a series of controller parameters can be configured, such as protocol, baud rate, controller mode, and whether to enable the terminal resistor.

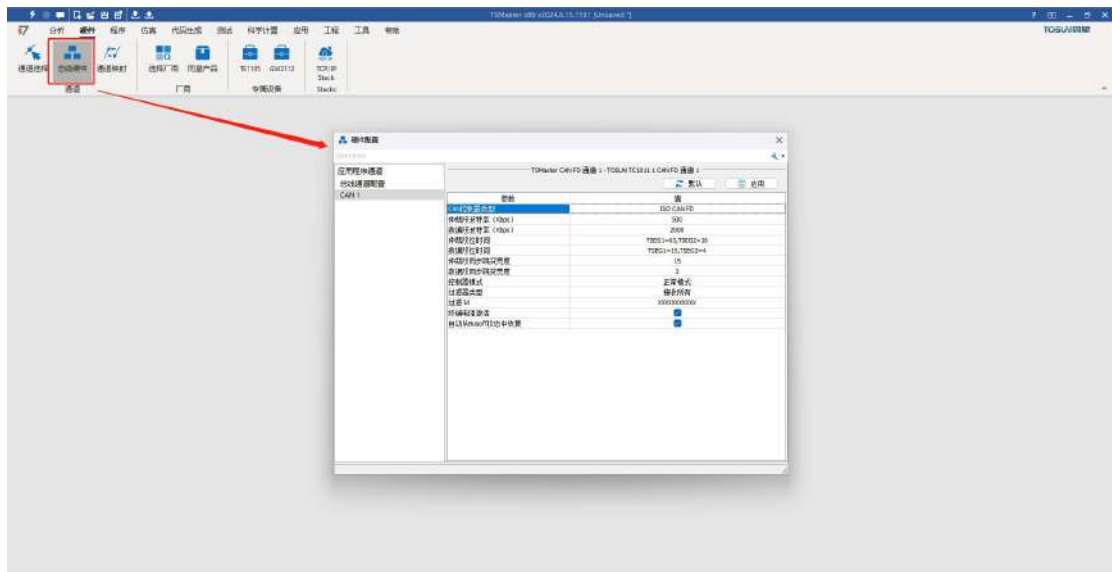

After the configuration, click Analysis->Start and connect the hardware to efficiently carry out works such as bus development, testing, ECU production line, etc. with the powerful TSMaster software. For more detailed instructions on using the TSMaster software, please refer to the TSMaster software manual and the quick start guide.

## 4. Inspection and Maintenance

The main electrical components of TO1013 device are semiconductor components. Although the equipment have a long service life, they may also accelerate aging and significantly reduce their service life under an incorrect environment. Therefore, during the use of the equipment, periodic inspection should be carried out to ensure that the use environment maintains the required conditions.

It is recommended to conduct inspections at least once every 6 months to 1 year. Under improper environmental, more frequent inspections should be conducted. As shown in the table below, if you encounter problems during maintenance, please read the following content to find the possible causes of the problem. If the problem still cannot be solved, please contact Shanghai TOSUN Technology Ltd.

Item	Inspection	Standard	Action
Power Supply	Inspect for voltage fluctuations at the power supply end	USB port +5V DC Power supply port +12V DC	Use a USB power meter/voltage meter to check the power input end. Take necessary actions to keep the voltage fluctuations within the acceptable range.
Surrounding Environment	Check the ambient temperature of the surrounding environment. (Including the internal temperature of enclosed environments)	-40°C~+80°C	Use a thermometer to check the temperature and ensure that the ambient temperature within in the acceptable range.
	Check the ambient humidity. (Including the internal humidity of enclosed environments)	The relative humidity must be within the range of 10% to 90%	Use a hygrometer to check the humidity and ensure that the ambient humidity within the acceptable range.
	Check for the accumulation of dust, powder, salt, and	No accumulation	Clean and protect the equipment.

	metal shavings		
	Check for any contact with water, oil, or chemical sprays on the equipment	No contact	Clean and protect the equipment if necessary.
	Check for the presence of corrosive or flammable gases in the equipment area	No presence	Inspect by the smell, or using a sensor.
	Check for levels of vibration and shock	Vibration and shock are within the acceptable range	Install padding or other shock-absorbing devices if necessary.
	Check for noise sources near the equipment	No significant noise source	Isolate the equipment from noise sources or protect the equipment.
Wiring Installation	Check the crimped connectors in the external wiring	Ensure enough space between the connectors	Visually inspect and adjust if necessary.
	Check for damage in the external wiring	No damage	Visually inspect and replace the wiring if necessary.

## 5. Appendix

### 30-1000MHz Radiated Emission (H)

#### EUT Information

EUT Name:

Model:

Client:

Op Cond: Power on

Operator: Tianji XU

Test Spec: EN IEC 61326-1 Class B

Comment:

Sample No:

## Sweep Setup: RE\_VULB9168\_pre\_Cont\_EN 55032\_30-1000 [EMI radiated]

Hardware Setup: RE\_VULB9168

Receiver: [ESR 3]

Level Unit: dBuV/m

Subrange	Step Size	Detectors	Bandwidth	Sweep Time	Preamp
30 MHz - 1 GHz	48.5 kHz	PK+	120 kHz	0.2 s	20 dB

RE\_VULB9168\_pre\_Cont\_EN 55032\_30-1000

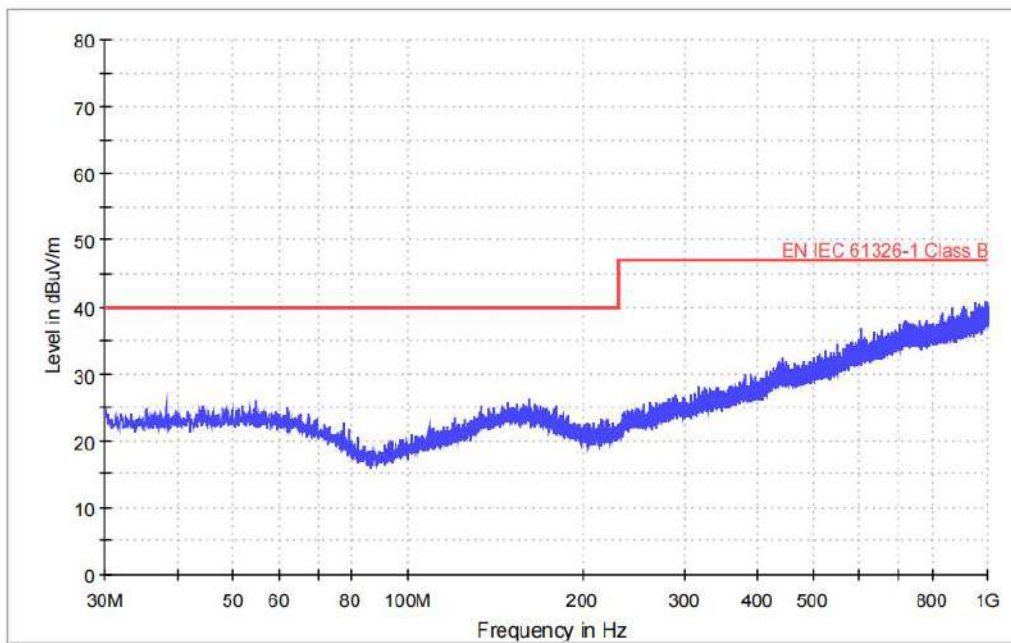

## Common Information

Equipment Name	Equipment ID
EMI Receiver	S1503109-YQ-EMC
Broadband Antenna	S1808296-YQ-EMC

# 30-1000MHz Radiated Emission (V)

## EUT Information

EUT Name:  
 Model:  
 Client:  
 Op Cond: Power on  
 Operator: Tianji XU  
 Test Spec: EN IEC 61326-1 Class B  
 Comment:  
 Sample No:

## Sweep Setup: RE\_VULB9168\_pre\_Cont\_EN 55032\_30-1000 [EMI radiated]

Hardware Setup: RE\_VULB9168  
 Receiver: [ESR 3]  
 Level Unit: dBuV/m

Subrange	Step Size	Detectors	Bandwidth	Sweep Time	Preamp
30 MHz - 1 GHz	48.5 kHz	PK+	120 kHz	0.2 s	20 dB

RE\_VULB9168\_pre\_Cont\_EN 55032\_30-1000

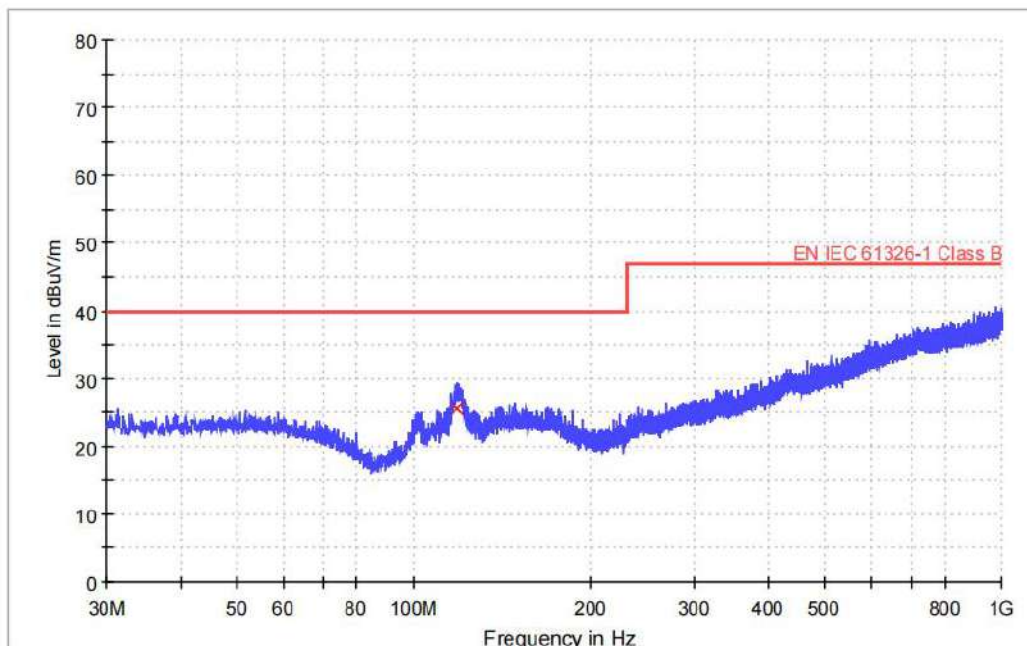



## Limit and Margin

Frequency (MHz)	QuasiPeak (dBuV/m)	Meas. Time (ms)	Bandwidth (kHz)	Height (cm)	Pol	Azimuth (deg)	Corr. (dB/m)	Margin - QPK (dB)
118.800000	25.6	1000.0	120.000	100.0	V	342.0	18.0	14.4

(continuation of the "Limit and Margin" table from column 16 ...)

Frequency (MHz)	Limit -QPK (dBuV/m)	Comment
118.800000	40.0	

## Common Information

Equipment Name	Equipment ID
EMI Receiver	S1503109-YQ-EMC
Broadband Antenna	S1808296-YQ-EMC

## Software

- Support CAN(FD)/LIN/FlexRay/SOME/IP and DoIP
- UDS diagnostics/ECU flashing/CCP/XCP calibration
- Embedded code generation/Application builder
- Encrypted release/Logging and bus replay
- Graphical programming/Residual bus simulation
- C and Python scripting
- Bus monitoring/Transmitting/Automated testing

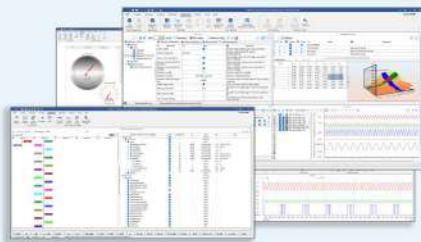

**TSMMASTER**

## Hardware

- 1/2/4/8/12-channel CAN FD/CAN to USB/PCIe device
- 1/2/6-channel LIN to USB/PCIe device
- Multi channel FlexRay/CAN FD to USB/PCIe device
- Multi channel automotive Ethernet/CAN FD to USB/PCIe device
- Automotive Ethernet media conversion device (T1 to Tx)
- Multi-channel CAN FD/Ethernet/LIN datalogger



TTS test systems

- CAN FD/CAN/FlexRay/LIN communication boards
- Relay and fault injection boards
- Resistors for sensor simulation
- Digital I/O, Analog I/O boards available

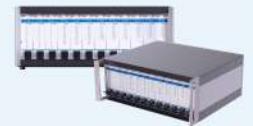

## Solutions

- Bus Conformance
- Network Automation Testing System
- Charging Testing System
- EMB Calibration Testing Equipment
- Information Security Solutions
- Steer-by-Wire Chassis Testing Solutions
- EOL Testing Equipment
- Motor Performance
- Durability Testing Solutions
- FCT



## About TOSUN

The core product, TSMaster, is a comprehensive tool for automotive R&D, testing, production, and after-sales. It integrates essential functions with hardware support to streamline processes and ensure precision, making it ideal for automotive professionals.

International Organization



Quality Assurance  
**ISO9001:2015**

CE Certification



**Contact Us :**

+86 21-5956 0506  
sales@tosunai.com

**website :**

www.tosunai.com

